

Telecommunications equipment – Subscriber equipment – Technical requirements for analogue handset telephony

Telekommunikationsutrustning – Abonentutrustning – Tekniska krav för analog telefoni via handmikrotelefon

Contents

	Page
0 Introduction	1
1 Scope	1
2 References	2
3 DC characteristics and feeding conditions	2
4 Electro-acoustic characteristics	2
5 Return loss	7

0 Introduction

This edition results from a general review of Swedish standards for attachment to a PSTN in order to align their mandatory content with the requirements of the teleterminal directive (91/263/EEC). Provisions regarding loudspeaking and headset functions have been deleted, and a number of other modifications have been made, mainly to make testing more efficient.

By this edition the Swedish language version of SS 63 63 41 is withdrawn. From now on the Swedish language version of standards for attachment to a PSTN will not be maintained.

1 Scope

This standard covers the handset voice telephony aspects of analogue connection of telephone sets to a public switched telephone network in Sweden. This standard also applies to payphones and to handset voice telephony functions of combined terminal equipment, e.g. facsimile apparatus with an integral handset.

The standard contains, except the normative requirements for connection, also informative recommendations in order to improve the acoustic performance of the telephone handsets. These recommendations have been written as notes.

2 References

The following standards contain requirements, which through reference constitute requirements of this standard.

ITU-T Recommendations:

- O.41 (1993) Psophometer for use on telephone-type circuits
 P.51 (1993) Artificial mouth
 P.57 (1993) Artificial ears
 P.64 (1993) Determination of sensitivity/frequency characteristics of local telephone systems
 P.79 (1993) Calculation of loudness ratings for telephone sets

3 DC characteristics and feeding conditions

The telephone set shall function and comply with all requirements of this specification for both polarities and for DC current between a lower and an upper limit. The DC current limits shall be determined by connecting the telephone set to a DC source with emf (E) and resistance (R) according to table 1.

Table 1 – Feeding conditions

Clause	Lower limit		Upper limit	
	E V	R Ω	E V	R Ω
4.4.2 4.9.3	50	2 800	50	1 600
4.4.3 4.5.2 4.9.4 4.9.6	50	1 600	50	1 600
5	36 ^{*)}	3 000 ^{*)}	60	1 200
all other clauses	38	2 300	60	1 200 ^{*)}
NOTE – The lower limit of the DC current shall be not less than 10 mA				

4 Electro-acoustic characteristics

4.1 General

The requirements below shall apply to the basic function of a handset telephone set, including requirements for receiver volume control.

Unless otherwise stated, the requirements shall apply within the DC limits defined in clause 3 and in the 300 – 3 400 Hz frequency band.

The handset shall be placed in the LRGP (Loudness Rating Guard-Ring Position) as defined in ITU-T P.64, annex C.

The acoustic interface at sending shall be MRP (Mouth Reference Point) as defined in ITU-T P.64, annex A. Sending in MRP shall be performed with an artificial mouth specified in ITU-T P.51. Unless otherwise stated, the sending level shall be -4,7 dBPa.

The acoustic interface at receiving shall be ERP (Ear Reference Point) as defined in ITU-T P.64, annex A. Measurement in ERP shall be performed with an artificial ear specified in ITU-T P.57. Unless otherwise stated, the applied electric signal shall have an emf of -12 dBV.

Unless otherwise stated, the measurements in electrical interfaces shall be performed with load and generator resistances of 600 Ω .

4.2 Measurement circuits

The circuits in figures 1, 2 and 3 shall be used for testing purposes. The telephone set shall be DC fed according to clause 3.

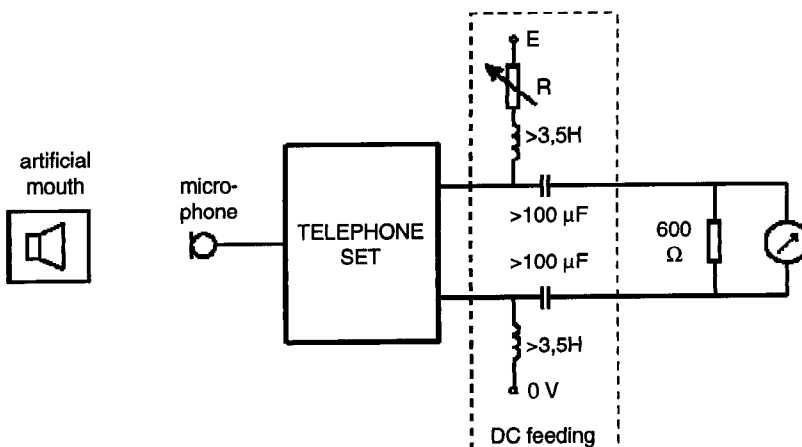

Figure 1 Sending measurement

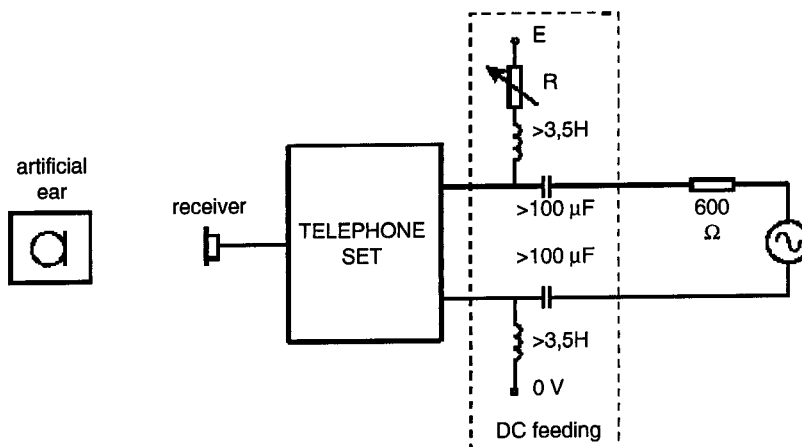

Figure 2 Receiving measurement

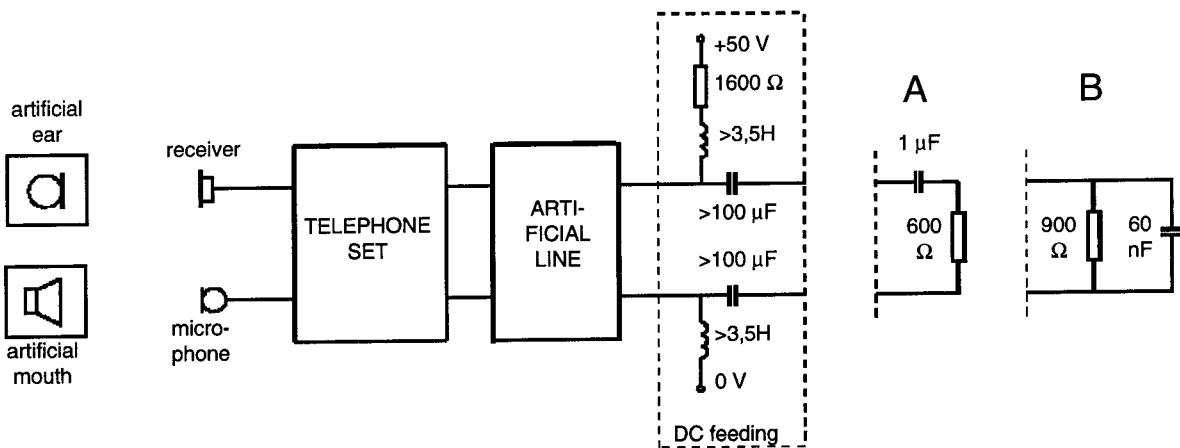

Figure 3 Sidetone measurement (note that two different line terminations, A and B, shall be used)

4.3 Frequency response

The frequency response curve shall fall within the masks given in figures 4 and 5. The measurement during sending shall be carried out with constant sinusoidal sound pressure (as a function of frequency). The measurement during receiving shall be carried out with constant emf.

Note: The 200 – 300 Hz frequency band is essential to the naturalness of speech. For this reason it is desirable that this band as well be reproduced and that the frequency response curves also lie above the dashed limits indicated in the figures.

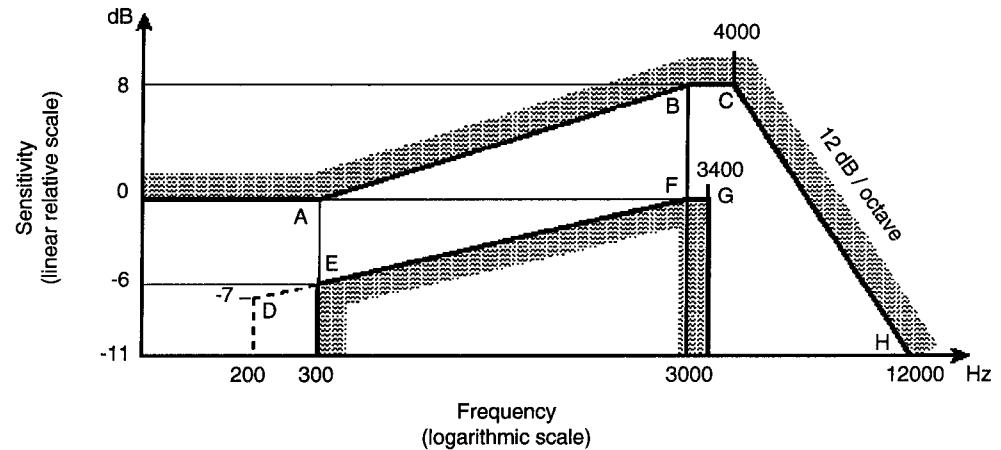

Figure 4 Sending frequency response curve

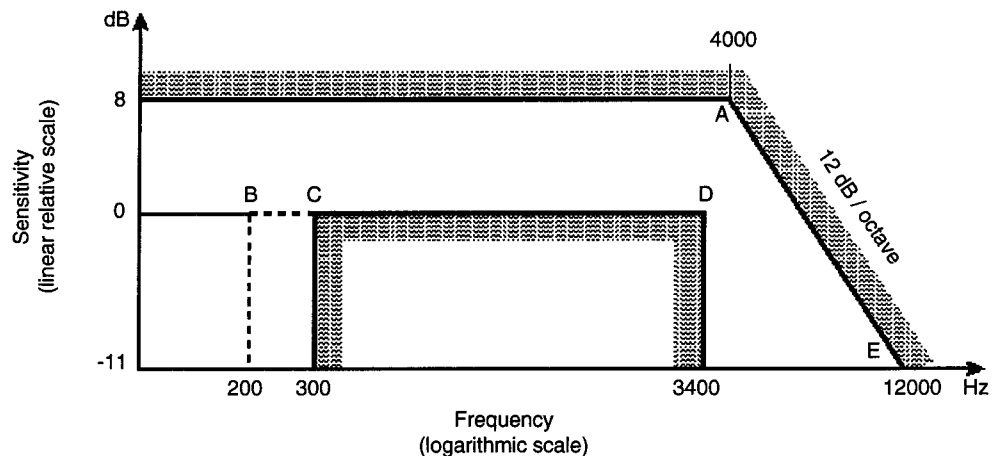

Figure 5 Receiving frequency response

4.4 Loudness rating

4.4.1 General

The electro-acoustic sensitivity shall be measured in accordance with ITU-T P.64.

SLR (Sending Loudness Rating) shall be calculated according to ITU-T P.79, formula 2-1, for the frequency bands 4 to 17 using $m = 0,175$ and the send weighting factors given in table 1/P.79.

RLR (Receiving Loudness Rating) shall be calculated according to ITU-T P.79, formula 2-1, for the frequency bands 4 to 17 using $m = 0,175$ and the receive weighting factors given in table 1/P.79.

STM (Sidetone Masking Rating) shall be calculated according to ITU-T P.79, formula 2-1, for the frequency bands 1 to 20 using $m = 0,225$ and the weighting factors given in table 3/P.79.

4.4.2 Sending and receiving

The loudness rating expressed as SLR and RLR shall lie within the masks given in figures 6 and 7, respectively.

Note: The figures also give the desired characteristics, as dashed curves.

For R values exceeding 2 800 Ω the lower limit shall be -3,5 dB down to 10 mA DC current.

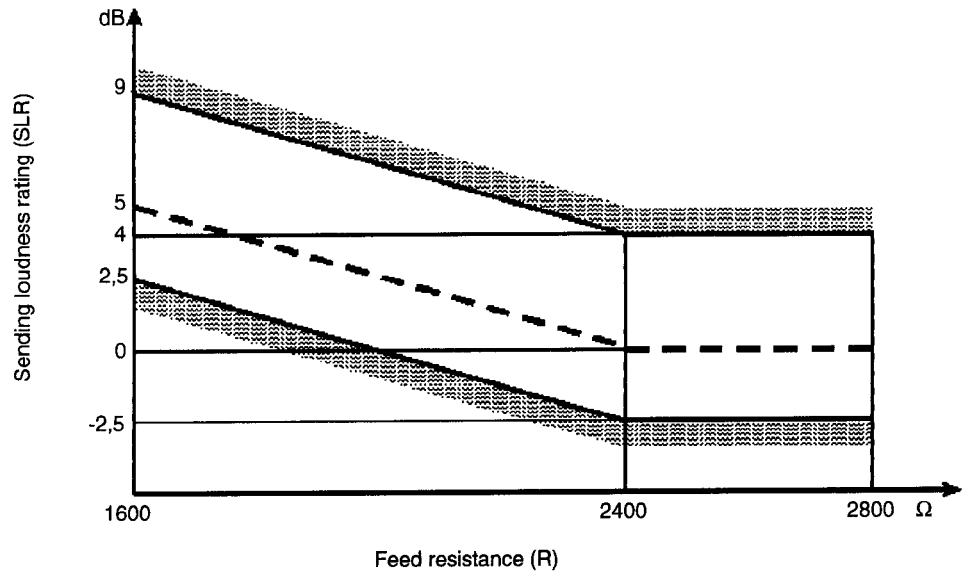

Figure 6 Sending Loudness Rating, SLR

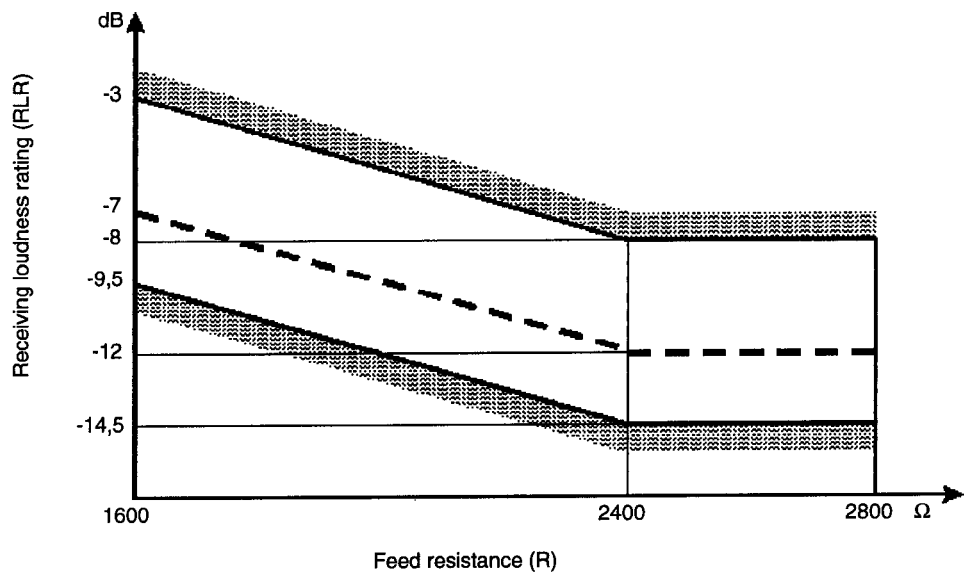

Figure 7 Receiving Loudness Rating, RLR

4.4.3 Sidetone

The sidetone attenuation expressed as STMR shall exceed 2 dB with artificial lines a) to d) connected and terminated according to figure 3.

- a) 0-4,5 km artificial line, 0,4 mm
- b) 0-7 km artificial line, 0,5 mm

in both cases terminated by 600 Ω in series with 1 μ F (termination A)

- c) 0-1 km artificial line, 0,4 mm
d) 0-1 km artificial line, 0,5 mm

in both cases terminated by $900\ \Omega$ in parallel with $60\ \text{nF}$ (termination B).

Note: It is desirable that STMR exceed $7\ \text{dB}$.

Artificial lines are shown in figures 8 and 9.

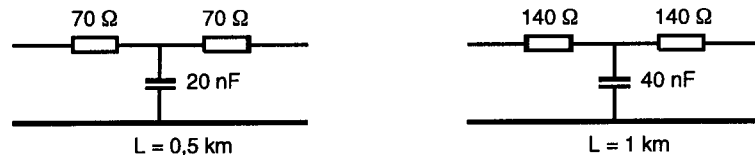

Figure 8 Artificial lines, 0,4 mm



Figure 9 Artificial lines, 0,5 mm

In order to produce longer artificial lines, 0,5 km links and/or 1 km links shall be connected in cascade.

4.5 Distortion

4.5.1 Distortion at sending and receiving

The sum of the 2nd and 3rd harmonics shall not exceed 10 % and the 3rd harmonic shall not exceed 5 %. Measurement shall take place in accordance with clause 4.3.

Note: It is desirable that the distortion does not exceed 7 and 3 %, respectively.

For sending, the sound pressure level $1\ \text{dBPa}$ applies in the 300 - 500 Hz frequency band and $-4\ \text{dBPa}$ in the 500 - 3 400 Hz frequency band. The sound pressures are defined in MRP. An emf of $-7\ \text{dBV}$ is applicable for receiving.

4.5.2 Sidetone distortion

The 3rd harmonic of the sidetone shall be less than 10 %. The sidetone distortion shall be measured at the same sound pressure levels as apply for measurement of sending distortion, and with conditions and terminations according to clause 4.4.3.

4.6 Acoustic shock

Note: The prevention of acoustic shock is a safety requirement arising from the Low Voltage Directive (73/23/EEC). In the absence of any relevant safety standard, a supplier's declaration may be based on the following recommendations.

The sound pressure level in ERP should not exceed $26\ \text{dBPa}$ (peak value) independent of the signal level at the input of the telephone set and the output voltage for any sound pressure level at the microphone should be less than $3\ \text{V}$ (peak value). The requirements should apply to all positions of any user accessible volume control.

The measurement should be made with an artificial ear according to clause 4.1 with signals applied in the interval 0 to $34\ \text{dBV}$.

4.7 Noise

For sending, the noise level shall not exceed -60 dBmp (measured with psophometric weighting curve in accordance with ITU-T O.41).

Note: It is desirable that the noise level does not exceed -65 dBmp.

For receiving, the noise level shall not exceed -49 dBPa, with A weighting.

Note: It is desirable that the noise level does not exceed -54 dBPa, with A weighting.

4.8 Regulation of the sending loudness

It shall not be possible for the user to adjust the sending loudness.

4.9 Receiver volume control

4.9.1 General

If the telephone set is provided with a user accessible volume control for the regulation of the receiving loudness the following requirements shall apply.

4.9.2 Frequency response

The requirements shall be in accordance with clause 4.3 and shall apply for all positions of the volume control.

4.9.3 Receiving loudness rating

With the volume control in the maximum position, RLR may decrease by a maximum of 18 dB relative to the dashed curve in figure 7. When measuring the maximum sensitivity the applied electrical signal shall have an emf of -30 dBV. Furthermore, for at least one position of the volume control and for all feed resistances, the RLR shall fall within the mask given in figure 7.

4.9.4 Sidetone

The sidetone expressed as STMR shall fulfil the requirements as stated in clause 4.4.3. The measurements shall be carried out with the volume control adjusted to bring the RLR as close as possible to -7 dB at 50 V emf and 1 600 Ω feed resistance.

4.9.5 Distortion at sending and receiving

The requirements shall be in accordance with clause 4.5.1. The measurements shall be carried out with the volume control adjusted to bring the RLR as close as possible to -7 dB at 50 V emf and 1 600 Ω feed resistance.

4.9.6 Sidetone distortion

The requirements shall be in accordance with clause 4.5.2. The measurements shall be carried out with the volume control adjusted to bring the RLR as close as possible to -7 dB at 50 V emf and 1 600 Ω feed resistance.

4.9.7 Noise

The requirements shall be in accordance with clause 4.7. The measurements shall be carried out with the volume control adjusted to bring the RLR as close as possible to -7 dB at 50 V emf and 1 600 Ω feed resistance.

5 Return loss

The return loss against the reference impedance Z_R shall exceed the limit given in figure 10. The reference impedance Z_R shall be made up of 270 Ω in series with a parallel combination of 750 Ω and 150 nF.

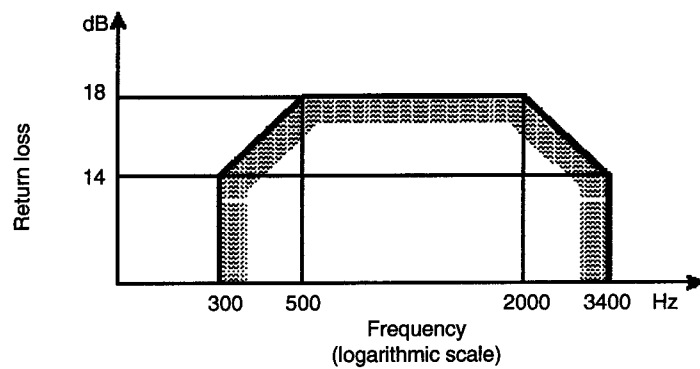

Figure 10 Minimum values of the return loss.