

## Telecommunications equipment - Private Branch Exchanges (PBXs) - Signaling requirements in digital interface for outgoing exchange line

*Telekommunikationsutrustning – Abonnentväxlar – Signaleringskrav i digitalt gränssnitt för avgående huvudledning*

### Contents

	Page
0 Introduction	1
1 Scope	1
2 Normative references	2
3 Signaling diagram	2
4 Requirements	2
4.1 General	2
4.2 Set-up and disconnection of calls	3
4.3 Blocking and unblocking	5
Annex A Signaling diagram (informative)	6

### 0 Introduction

This edition results from a general review of Swedish Standards for attachment to a PSTN in order to align their mandatory content with the requirements of the teleterminal directive (91/263/EEC) and from the withdrawal of SS 63 63 27 as a standard for regulative requirements. A number of provisions have been deleted, some provisions have been transferred to informative parts of the standard and some other modifications have been made.

By this edition the Swedish language version of Ss 63 63 31 is withdrawn.

### 1 Scope

This standard covers the requirements for signaling for outgoing calls according to the national signaling system P7 in a digital interface towards a public switched telephone network on a one-way or both-way exchange line.

## 2 Normative references

The following standards contain requirements, which through reference, constitute requirements of this standard. At the time of publication, the editions indicated were valid. All standards are subject to revision, and parties to agreements based on this standard are encouraged to investigate the possibility of applying the most recent editions of the standards listed below. Members of IEC and ISO maintain registers of currently valid International Standards.

- SS 63 63 24 Telecommunications equipment – Private Branch Exchanges (PBXs) - Signalling requirements in analogue interface for outgoing exchange line
- SS 63 63 29 Telecommunications equipment – Private Branch Exchanges (PBXs) – Transmission requirements for digital interfaces
- SS 63 63 32 Telecommunications equipment – Private Branch Exchanges (PBXs) – Signaling requirements in digital interface for incoming exchange line
- SS 63 63 42 Telecommunications equipment – Subscriber equipment – Attachment requirements for analogue connection to a public switched telephone network

## 3 Signaling diagram

The signaling diagram will be found in annex A. This signaling diagram provides a description of the performance and characteristics of a public switched telephone network with respect to signaling according to signaling system P7 for different connection cases and call processes in outgoing traffic from the PBX.

Signaling system P7 is a national signaling system for channel-associated signaling with a digital PBX connected to a digital local exchange. In the case of PBXs with a digital interface, signaling system P7 may also be used for connection to an electromechanical local exchange via signal converter equipment, see SS 63 63 24.

The attached signaling diagram covers variations in the performance and characteristics of the public switched telephone network between different types, or variants, of public exchange systems and between different connection forms.

The signaling diagram is intended to serve information on the performance and characteristics of the telephone network. In this context, the parameter values specified in the signaling diagram with respect to the performance of the PBX are to be regarded as typical values, etc. Thus the parameter values, etc., specified in the signaling diagram do not constitute any mandatory requirements imposed on the PBX in excess of what is explicitly specified as requirements in clause 4 below. The object of those requirements is to secure basic functions of vital importance under normal circumstances and in normal connection cases.

**This means that compliance with the requirements set forth in this standard does not provide any guarantee of correct performance of the equipment when connected to the telephone network.**

## 4 Requirements

### 4.1 General

#### 4.1.1 Traffic direction

NOTE: The line may have a one-way traffic configuration, i.e. only for calls from the PBX to the telephone network, or a both-way traffic configuration. In the latter case, the PBX shall, when idle, enter the state defined in standard SS 63 63 32 for incoming traffic.

#### 4.1.2 Interface

This standard refers to signaling in a digital interface with a frame and multiframe structure and associated functions in accordance with standard SS 63 63 29. Two signaling channels are used, a and b; in the multiframe, they are used in both directions.

NOTE: Signaling channel as used here refers to one of the four signaling bits contained in time slot 16 in each transmission direction for each circuit concerned.

The signaling process also includes certain tone messages and, if used, multifrequency tone signaling, in the voice frequency channels.

#### 4.1.3 Idle state

When in the idle state, the PBX shall send signaling states having the value of 1 in signaling channel a and the value of 0 in signaling channel b.

#### 4.1.4 Recognition time

NOTE: Recognition refers to the detection of signaling states in the signaling channels in the receive direction (a<sub>b</sub> and b<sub>b</sub>, respectively) in the digital interface towards the PBX.

It is recommended that switchover to signaling states with the duration of < 10 ms should not be recognized and switchover to a signaling state with the duration of > 15 ms should be recognized.

### 4.2 Set-up and disconnection of calls

#### 4.2.1 Call request

A seizure signal is transmitted to the telephone network by assigning the value of 0 to the signaling state in signaling channel a.

#### 4.2.2 Dial tone

A dial tone is sent from the public exchange to indicate readiness to receive address information.

When sending address signals in an automatic mode the PBX shall be equipped with a dial tone detector or a timer for waiting before start of sending address signals. The requirements set forth in SS 63 63 42, clause 4.8.1, shall be fulfilled.

The levels in x dBm set forth in SS 63 63 42, clause 4.8.1.2, shall be replaced in the following way: -5 dBm is replaced by 0 dBm and -35 dBm is replaced by -25 dBm.

#### 4.2.3 Address signaling

For the purpose of address signaling, the following methods shall be used:

- decadic pulsing (loop-disconnect signaling), in accordance with clause 4.2.4, in signaling channel a, or
- multifrequency tone signaling, in accordance with clause 4.2.5, in the voice frequency channel.

#### 4.2.4 Decadic pulsing (loop-disconnect signaling)

4.2.4.1 A digit having a value of n is represented by n + 1 pulses.

4.2.4.2 A digit pulse shall consist of a signaling state having the value of 1 for  $60 \pm 5$  ms.

4.2.4.3 An interval between pulses within a pulse train representing one digit shall consist of a signaling state having the value of 0 for  $40 \pm 5$  ms.

4.2.4.4 An inter-digit pause, i.e. the time elapsing between the end of the last pulse of a digit and the start of the first pulse of the next digit, shall consist of a signaling state having the value 0 for > 500 ms. For pulsing in an automatic mode the inter-digit pause shall be < 900 ms.

#### 4.2.5 *Dialling with DTMF*

The DTMF sender shall fulfil the requirements set forth in SS 63 63 42, clause 4.8.2. The absolute levels in x dBm set forth in SS 63 63 42, clause 4.8.2.2, shall be replaced by the following levels expressed in dBm0:

- high frequency group: -9 dBm0 +4/-6 dB
- low frequency group: -11 dBm0 +4/-6 dB

However, the level of the higher frequency component in the compound signal shall be  $2 \pm 2$  dB above the level of the low frequency component.

#### 4.2.6 *Call metering signals*

NOTE: As an option, the signaling system allows transmission of call metering signals. The call metering signals are transmitted in signaling channel bb, by means of pulses with a signaling state having the value of 1. The timing is given in the signaling diagram in annex A. There are, however, no approval requirements for this supplementary service.

#### 4.2.7 *Register recall*

NOTE: In connection with register recall, if implemented, the register recall signal should in conversation state consist of a signalling state in signaling channel af, having the value of 1 and lasting for  $90 \pm 40$  ms. There are, however, no approval requirements for this supplementary service.

#### 4.2.8 *Clear-forward signal*

A clear-forward signal is transmitted by assigning the value of 1 to the signaling state in signaling channel af.

#### 4.2.9 *Disconnection*

**4.2.9.1** When a call from the PBX is disconnected before reception of an answer, the line shall not be seized for a new call over the public network within at least 1 s after a clear-forward signal has been sent.

**4.2.9.2** When a call from the PBX is disconnected after reception of an answer, but before a clear-back signal has been received, the line shall not be seized for a new call over the public network within at least 1 s after the idle state has been received in signaling channel ab.

**4.2.9.3** When a call from the PBX is disconnected after reception of a clear-back signal, the line shall not be seized for a new call over the public network within at least 1 s after a clear-forward signal has been sent.

**4.2.9.4** The requirements set forth in clauses 4.2.9.1–4.2.9.3 represent the minimum functionality and time limits that may be applied on a general basis to different types of public exchange systems in accordance with the attached signaling diagram. In addition, a PBX may incorporate logical functions and supplementary time limits for the initiation and supervision of the disconnection process which are adjusted to different versions of the signaling diagram, depending on the type of public exchange system to which the PBX is connected.

Therefore, deviations from the requirements set forth in clauses 4.2.9.1–4.2.9.3, due to the PBX operating on the basis of differentiated criteria adapted to the local exchange system concerned, will be accepted if the supplier is able to demonstrate that correct performance will be achieved in relevant connection cases.

#### 4.2.10 *Automatic repeat call attempts*

For automatic repeat call attempts in the event of an unsuccessful calling operation, the requirements set forth in SS 63 63 42, clause 4.8.3, shall be fulfilled.

#### **4.2.11 Signaling requirements for external call transfer**

External call transfer may be performed in a PBX or in a PBX network if the incoming (analogue or digital) exchange line is connected to a digital public exchange, and if clearing signals from the incoming to the outgoing exchange line, or vice versa, are forwarded within 3 s.

#### **4.3 Blocking and unblocking**

**4.3.1** When a signaling state having the value of 1 is received (in the idle state) in signaling channel  $b_b$ , the line shall be blocked for calls over the telephone network.

**4.3.2** When a signaling state having the value of 0 is received in signaling channel  $b_b$  with the line being blocked, the line shall be unblocked.

**Annex A**  
(informative)

**Exchange line P7 signaling, PBX/A-subscriber -> Local exchange**

This annex is a specification of the national signaling system P7 for signaling in a digital interface towards an exchange line between a public exchange and a PBX.

Signaling system P7 is used with digital PBXs connected to a digital public exchange.

With signal converters the signaling system may also be used for connection of a digital exchange line to an analogue exchange as well as to an analogue PBX.

No	Signal or state	G1 at ET		G2 at DXL	
		a	b	a	b
		t			t
1	Idle	↓			↓
2	Seizure	00			50
3	Dial tone <sup>1)</sup>				
4	Dec. puls digit "1" <sup>2)</sup>	01 02 03 04			51 52 53 54
5	Digit "0"	05 06			55 56
6	Disconnect of reg.				
7	Answer	07			57
8	1st meter pulse	08 09			58 59
9	Conv. state				
10	Repeat meter pulse	10 11			60 61
11	Clear-back <sup>3)</sup> after No. 9	12			62
12	Clear-forward	13 14			63 64
13	Re-answer after No. 11	15			65
14	Forced release after No. 11	16 17			66 67

No	Signal or state	G1 at ET		G2 at DXL	
		a	b	a	b
		t			t
15	Clear forward after No. 9	↓ 18			↓ 68
16	Clear-back or forced release	19			69
17	New A off-hook after No. 15 <sup>4)</sup>	20			70
18	Clear-forward after Nos. 2-6	21			71
19	Block. after No. 1	22			72
20	Unblock.	23			73
21	Reg. recall signal after No. 9	24 25			74 75

- 1) Sent from the local exchange.
- 2) As an alternative, digits may be sent using MF pushbutton dialling (DTMF).
- 3) In the case of electro-mechanical exchanges, a clear-back signal may be sent from the exchange in certain connection and traffic cases.
- 4) Does not apply to calls from an extension.

**Time limits**

Time of recognition of approval bit modification in the interface.

G1 = 10 - 15 ms

G2 = 10 - 15 ms

$\left. \begin{array}{l} t00 \rightarrow t01 \\ t04 \rightarrow t05 \end{array} \right\} < 15 \pm 1 \text{ s (Time supervision of dialling)}$

$t04 \rightarrow t05 > 250 \text{ ms} = \text{approved digit}$

$t07 \rightarrow t08 = 150 \pm 15 \text{ ms}$

$\left. \begin{array}{l} t08 \rightarrow t09 \\ t10 \rightarrow t11 \end{array} \right\} = 160 \pm 15 \text{ ms}$

$t08 \rightarrow t10 = \text{min } 550 \text{ ms}$

$t12 \rightarrow t15 < 1,5 \text{ s}$  for periodic clearing from B-party PBX, otherwise subscriber-controlled.

$t12 \rightarrow t16 = 90 \text{ s alt } 2\text{--}3 \text{ min}$

$\left. \begin{array}{l} t64 \rightarrow t50 \\ t67 \rightarrow t50 \\ t68 \rightarrow t50 \\ t71 \rightarrow t50 \end{array} \right\} > 1 \text{ s}$

$t66 \rightarrow t67 = \text{Line lockout pending clear-forward signal}$

$\left. \begin{array}{l} t51 \rightarrow t52 \\ t53 \rightarrow t54 \\ t55 \rightarrow t56 \end{array} \right\} = 60 \pm 5 \text{ ms}$

$t52 \rightarrow t53 = 40 \pm 5 \text{ ms}$

$t54 \rightarrow t55 = \text{min } 500 \text{ ms (nom } 535 \text{ ms)}$

$t63 \rightarrow t14 > 250 \text{ ms (approved clear-forward signal)}$

$t68 \rightarrow t70 = 2\text{--}3 \text{ s}$

$t74 \rightarrow t75 = 90 \pm 40 \text{ ms}$

Note: Time limits and parameter values indicated are values typical of PBX equipment.

Sequence chart

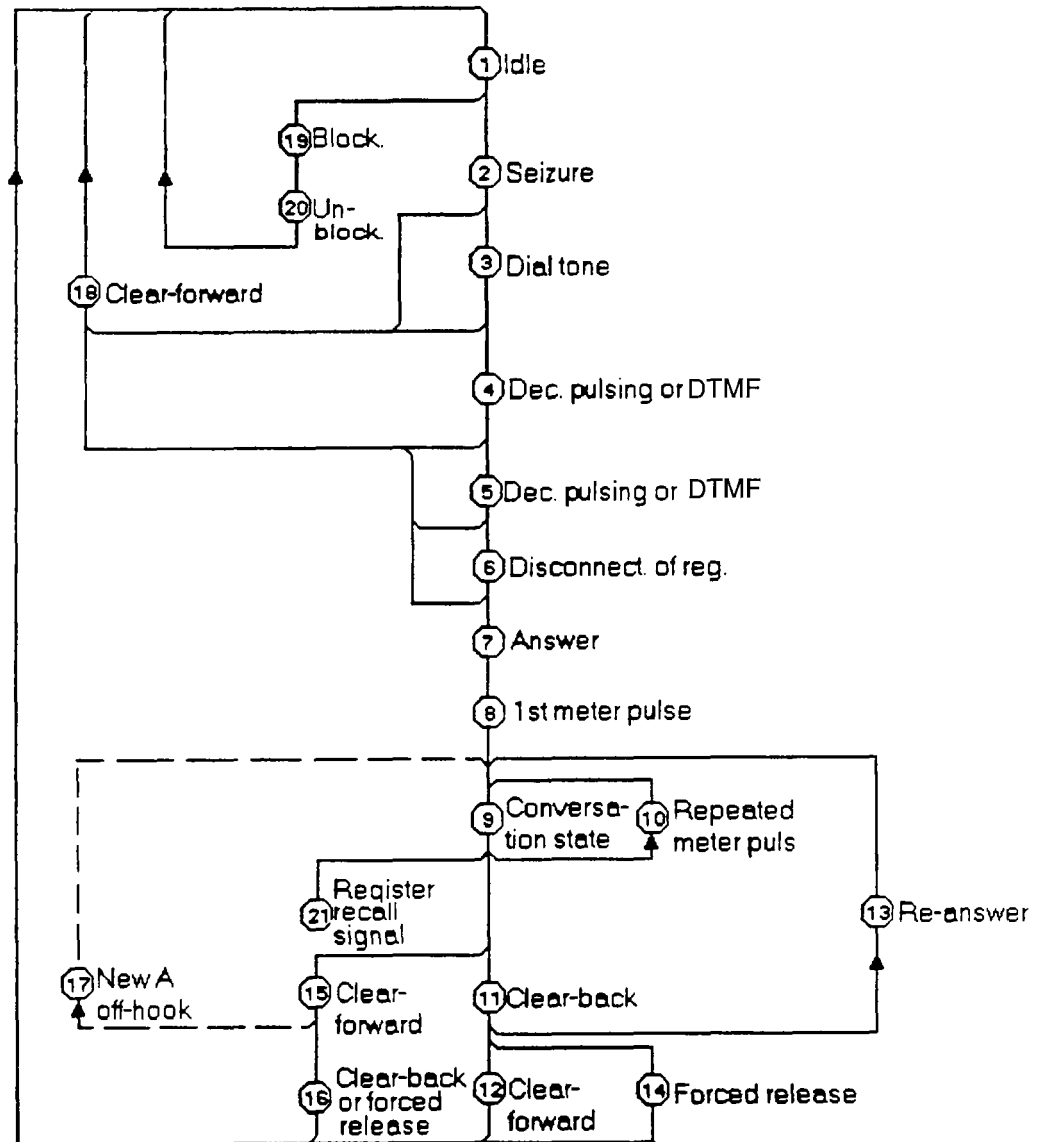

Interface

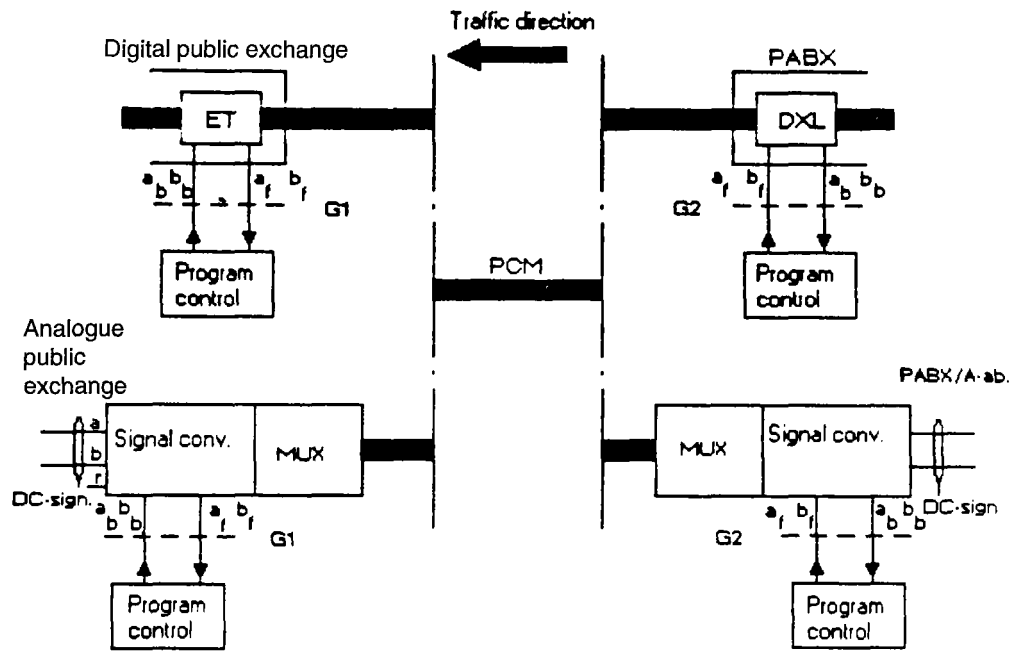

Legend

- $a_f, b_f$  Signaling bits in the forward direction (T16)
- $a_b, b_b$  Signaling bits in the backward direction (T16)
- Bit value "1"
- Bit value "0"
- Bit value "1" or "0"
- G1, G2 Interface designation
- ET Exchange Terminal
- DXL Digital Exchange Line
- T16 Time slot 16